



LADX
18M MULTI KIT //

v0823

 **BANAIR**

GAME CHANGING SPECIALIST ACCESS SYSTEMS //



18M MULTI KIT//

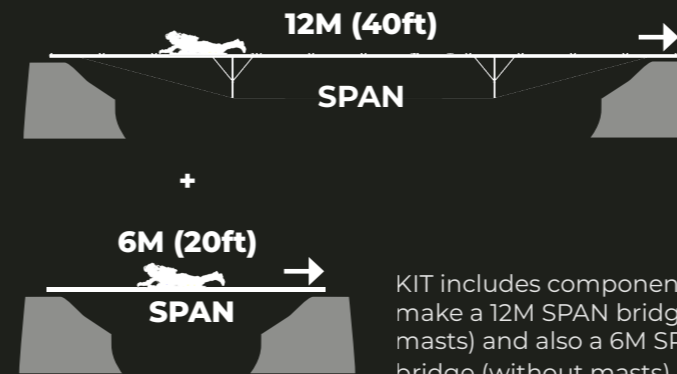

KIT includes components to make a 12M SPAN bridge (with masts) and also a 6M SPAN bridge (without masts)



STRUCTURAL ALUMINIUM

Construct the bridge you need **FAST** using sectional 1.5m components, all which condense into heavy duty bags



<30 MINS
Assemble &
Launch



200KGS
CAPACITY

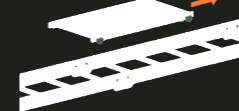

PATENTED TROLLEY

Engages into ladder stiles and cannot disengage without positive user release mechanism



LADX

18M MULTI KIT//

HEAVY DUTY BAGS



1.7M (67IN)

1-2 MAN EACH BAG CARRY



KIT includes components to make a 12M SPAN bridge (with masts) and also a 6M SPAN bridge (without masts). All portable within 5 heavy duty duffle bags.

LADX is unique compared with other traditional ladder systems in that each ladder section connects in perfect linear alignment with its neighbor - one continuous, heavy duty ladder, rather than over lapping staggered joints.

ALLOWS TACTICAL GROUND UNITS AN ENTIRELY NEW & INNOVATIVE SOLUTION TO SAFELY MOVE PERSONNEL & EQUIPMENT ACROSS ANY GAP UP TO 12M AND UNDER 500LBS. THE 18M MULTI KIT INCLUDES //

6M SPAN BRIDGE



12M SPAN BRIDGE

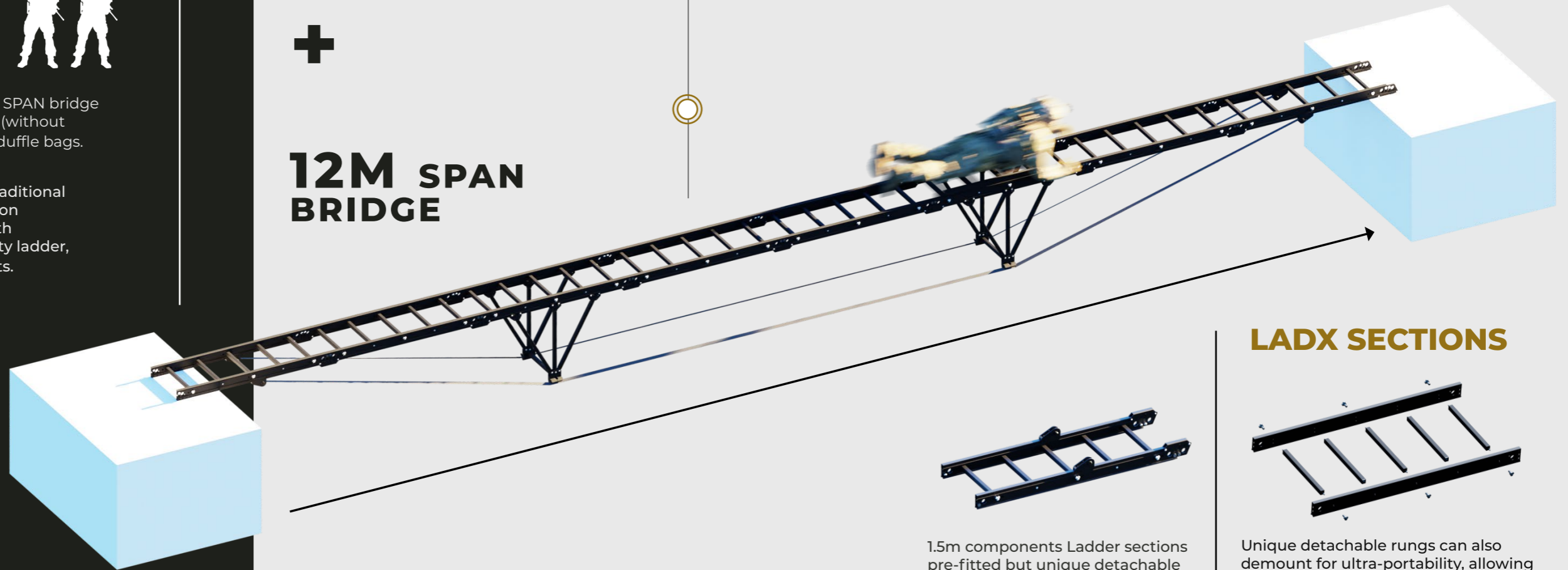
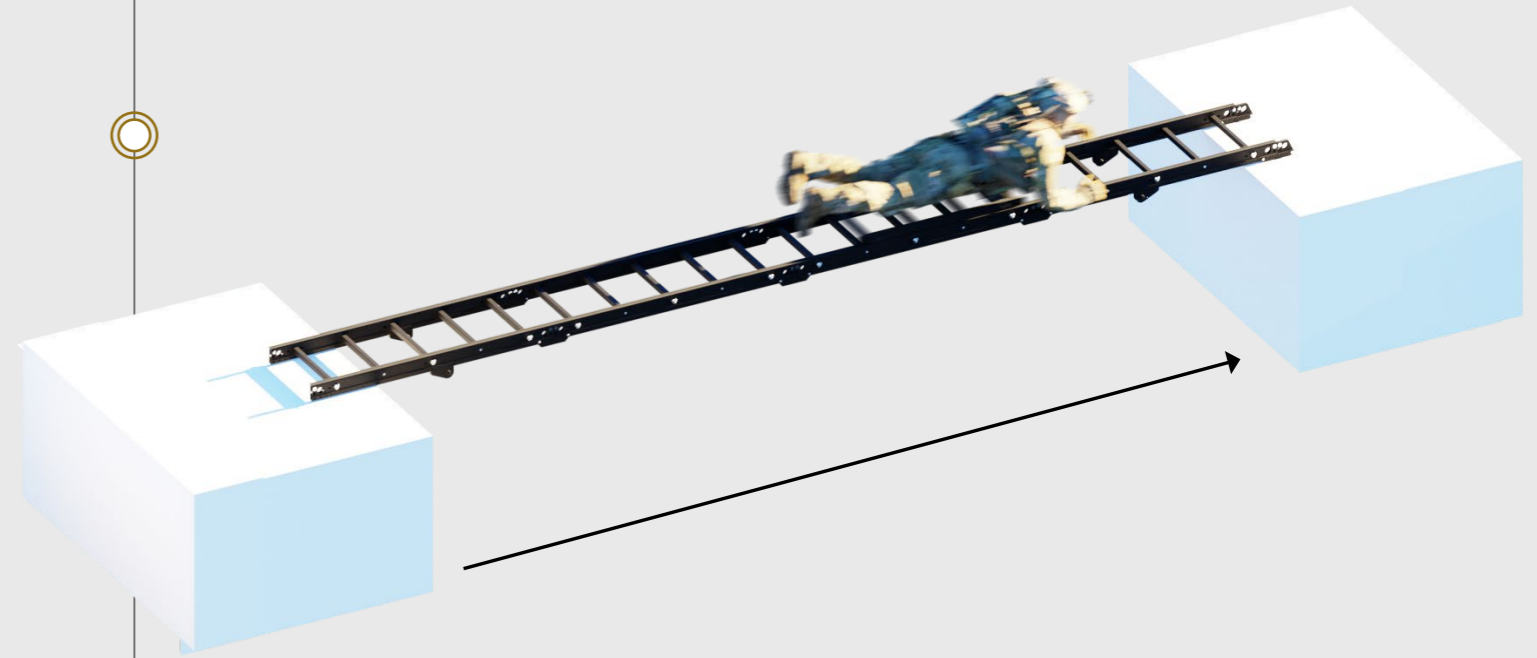

LADX SECTIONS

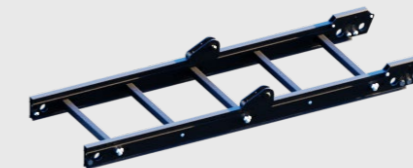

1.5m components Ladder sections pre-fitted but unique detachable rung design to facilitate the ultimate in portability

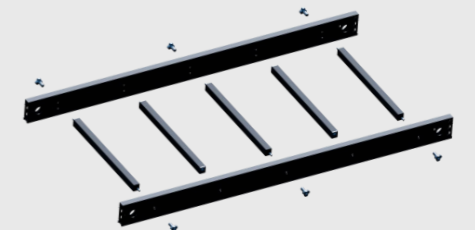

Unique detachable rungs can also demount for ultra-portability, allowing access into tight environments and efficient carrying between locations



LADX™

18M MULTI KIT//



OPERATION//

Ladder rungs demount for ultra-portability, allowing access into tight environments and efficient carrying between locations

End connector over-center latches connect with over 1500lbs of holding force each side allowing multiple LADX sections and attachments to securely fit in perfect linear alignment

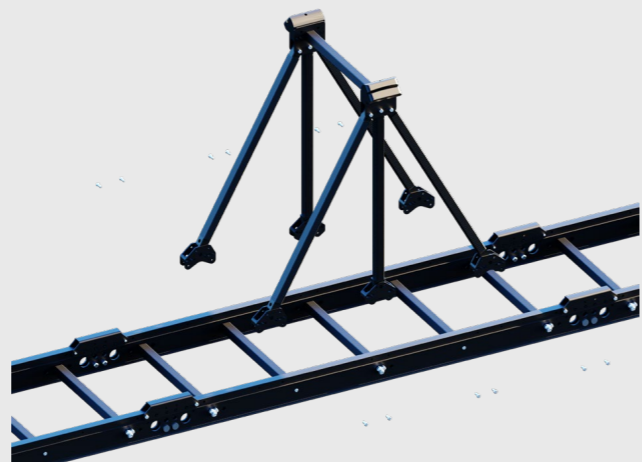
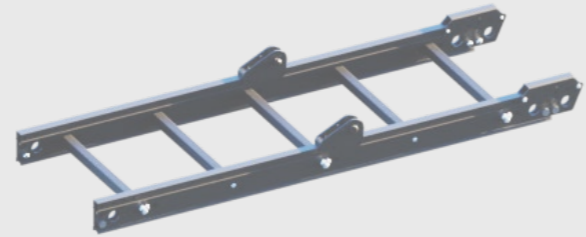
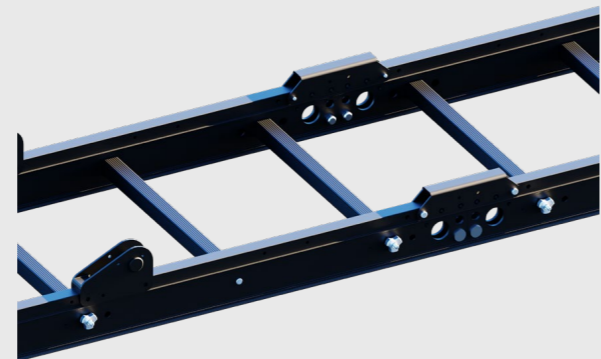
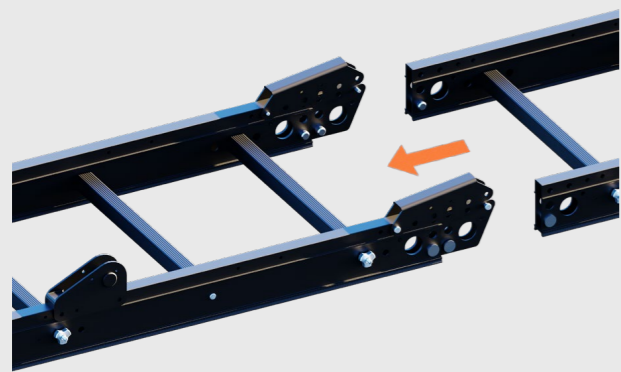

x2-4
To Operate

Join steel wires to required length and pattern for proposed span. Ensure bridge substantially level about transverse cross-section before operation. ROTATE BRIDGE 180 degrees. Trolley engages with LADX stile sections

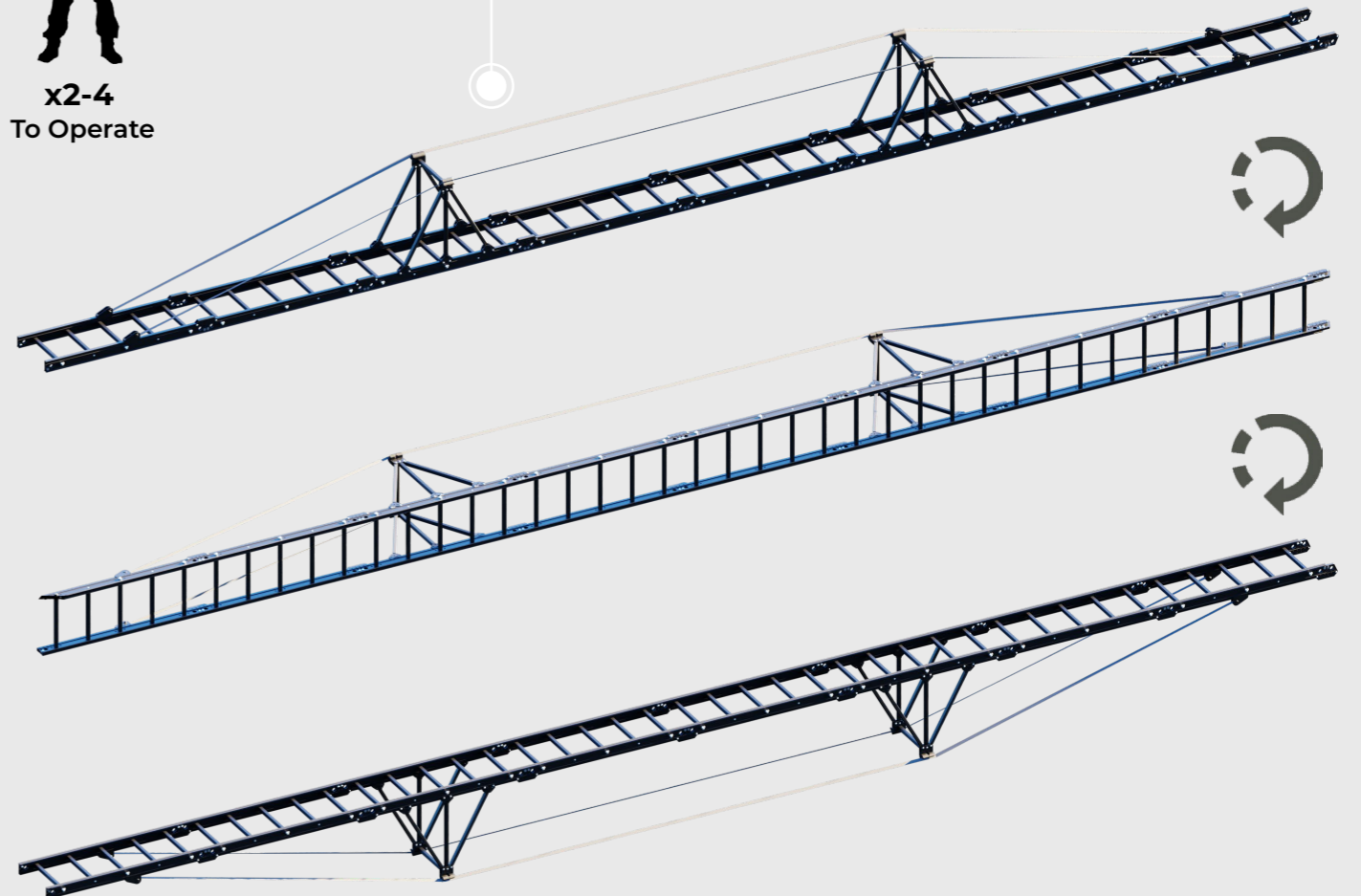

LADX

18M MULTI KIT //

IN COMBAT AND ACROSS THE GLOBE, THERE
ARE PLACES OUT OF REACH FOR SOF, THAT
THIS SYSTEM CAN BRING INTO REACH



Copyright © Bright Structures Ltd, 2023

VAT Registration: 242 4124 45

DUNS 221523146 ; Exostar EXO117544241 ; NATO Ncage U19F4

BAN-AIR.COM // LADX

SALES@BAN-AIR.COM